



BEVERAGE-AIR

Project: _____	AIA#
Item: _____	
Location: _____	SIS#
Approved: _____	

DZ24 DUAL ZONE: BAR EQUIPMENT

BAR EQUIPMENT - BAR MOBILE DZ24 Solid Door Dual Zone

MODEL:
DZ24-1-B

**5 Year Parts/Labor Warranty Available
7 Year Compressor Warranty**



CABINET CONSTRUCTION

- Exterior features durable black painted steel
- Interior is galvanized steel with reinforced stainless steel floor
- Stainless steel top with black glass rails
- Stainless steel drip tray for easy cleaning
- Full electronic control
- 3-in-1 Draft solution uses a single stainless-steel tap to serve different beverages, such as wine, beer, and coffee (or other non-alcoholic beverages) through silver-lined, anti-microbial tubing that is 100% effective against the top 4 beverage spoiling bacteria
- Dual zone models feature 2 independent compartments that allow independent temperature in each section
- Unit has a minimum variance of +/-15°F, and maximum of 20°F depending on condition
- 100% portable with waste bottle to capture beer/wine from drain
- Magnetic gasket provides positive door sealing
- Self-closing door with lock standard
- 3" Insulated tower with dual faucet, standard
- Holds up to (4) 1/6 kegs in each section
- Four-inch (4") deavy duty casters with two (2) brakes

OPTIONS & ACCESSORIES

- 3 Year parts/labor standard, additional 2 year warranty available
- Stainless steel interior
- Tap Locks
- 1- 4 Tap insulated stainless towers/taps
- No draft arm with hole cover

REFRIGERATION SYSTEM

- Refrigeration system uses R134a refrigerant to comply with all environmental concerns
- Automatic, non-electric defrost
- Epoxy coated evaporator coil
- Left hand compartment maintains 32°-40°F, Right hand maintains 50°-65°F



Please verify qualifying units by visiting:
www.energystar.gov/cfs

3779 Champion Blvd., Winston-Salem, NC 27105
1-888-845-9800 Fax: 1-336-245-6453
Beverage-Air.com Sales@beva.com



BEVERAGE-AIR

MODEL	DZ24-1-B
EXTERNAL DIMENSIONAL DATA	
Width Overall	24"
Depth Overall (with handle)	29 ³ / ₈ "
Height Overall (with casters)	53"
Number of Doors	1
Depth with Door Open 90°	50 ⁷ / ₈ "
Door Openings (in)	20" x 27 ³ / ₄ "
INTERNAL DIMENSIONAL DATA	
NET Capacity Freezer (cubic ft.)	(L) 3.72, (R) 3.72
Internal Width Overall (in)	10"
Internal Depth Overall (in)	18 ¹ / ₈ "
Internal Max Height Overall (in)	29 ¹ / ₂ "
ELECTRICAL DATA	
Full Load Amperes	4.0
REFRIGERATION DATA	
Horsepower	1/5
Capacity (BTU/Hr)	1110
Heat Rejection (BTU/Hr)	1665
Charge (lbs/grams)	0.1433/65
SHIPPING DATA	
Gross Weight - Crated	220 lbs
Height - Crated	64"
Width - Crated	27"
Depth - Crated	31"

Bar Equipment - Dual Zone Bar mobile Model: DZ24-1-B

Model Views

Required Clearance: 5 ¹/₄" Bottom

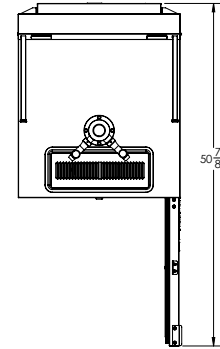

PLAN VIEW

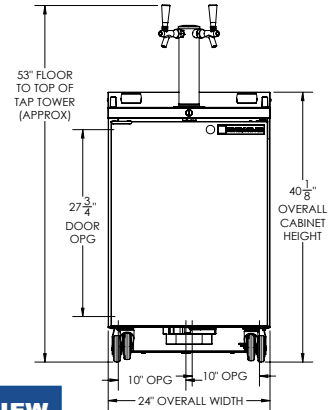

ELEVATION VIEW

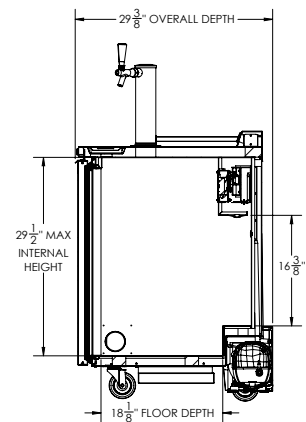

SIDE VIEW



ELECTRICAL CONNECTION



115/60/1
NEMA 5-15P

Unit pre-wired at factory and include 8' long cord and plug set.